



SERVICE MANUAL BDC-44

VERSION 1.2



EC DECLARATION OF CONFORMITY
in accordance with Appendix II sub A of Directive 2006/42/EC

BLASTRAC B.V.
Utrechthaven 12
NL - 3433 PN NIEUWEGEIN
Tel: 0031 (0)30 601 88 66
Fax: 0031 (0)30 601 83 33
Info@Blastrac.nl
The Netherlands

Declare under our sole responsibility that the machine as described below conforms with the Health and Safety requirements of the European Directive of the machine Safety.

In case of changes to the machine without our written authorization this declaration loses its validity.

Model: **BLASTRAC BDC-44** **Serial number:**

1. satisfies the conditions set out in the Machine Directive (Directive 2006/42/EC); Low voltage directive (2006/95/EC, as last amended; EMC directive 2004/108/EC, as last amended)
2. satisfies the following harmonized standards:
NEN-EN 349, NEN-EN 418, NEN-EN 294 and NEN-EN 60204

Nieuwegein

Michiel Kalisvaart



Index

1. Spare parts	04
Contact	13



1. Spare parts

Fig. 01

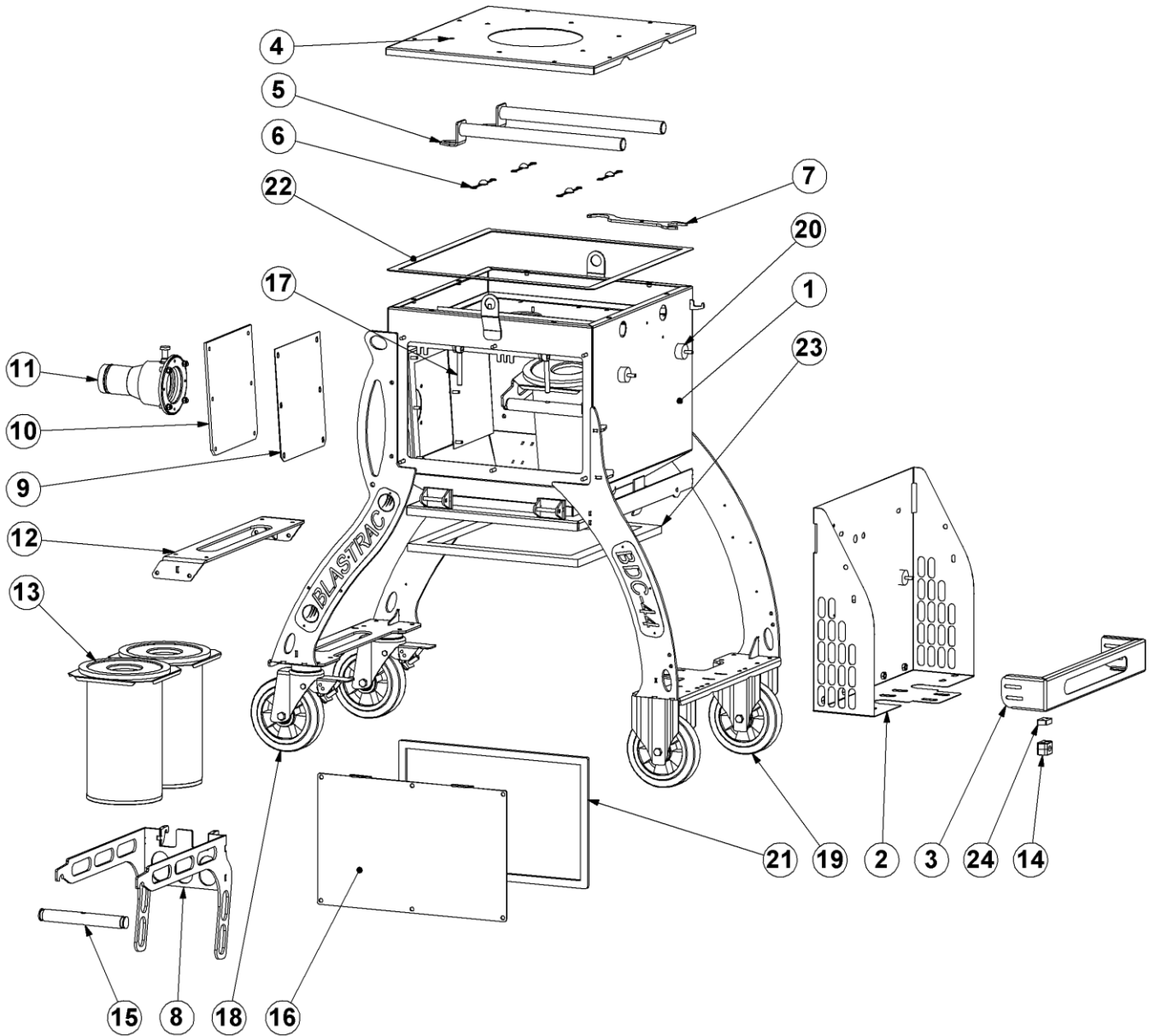

Fig. 01

Item	Part number	Description	Qty.
1	E09751	Filter house	1
2	E09912	Compressor cover	1
3	E07646	Compressor protection plate	1
4	E09890	Top cover	1
5	E09889	Pulse tube	2
6	E07763	Divider	4
7	E09767	Pulse tube key	1
8	E09893	Filter bracket	2
9	E09892	Filters secure plate	1
10	E09891	Rubber impact plate	1
11	K950171	Connector kit	1
12	E09888	Back legs bracket	1
13	E10218	Cartridge filter	4
14	999-9153	Pipe clamp 16mm (set)	1
15	E09895	Locking bar	2
16	E09896	Door filter house	1
17	-----	Eye bolt M12x100	2
18	E06875	Castor wheel	2
19	E06876	Wheel	2
20	999-9106	Shock absorber A40-20	4
21	B21189	Adhesive rubber seal 20x10	1,8m
22	E00649	Adhesive rubber seal 25x5	2,5m
23	E01309	Adhesive rubber seal 40x20	2,1m
24	E11033	Distance plate	1

Fig. 02

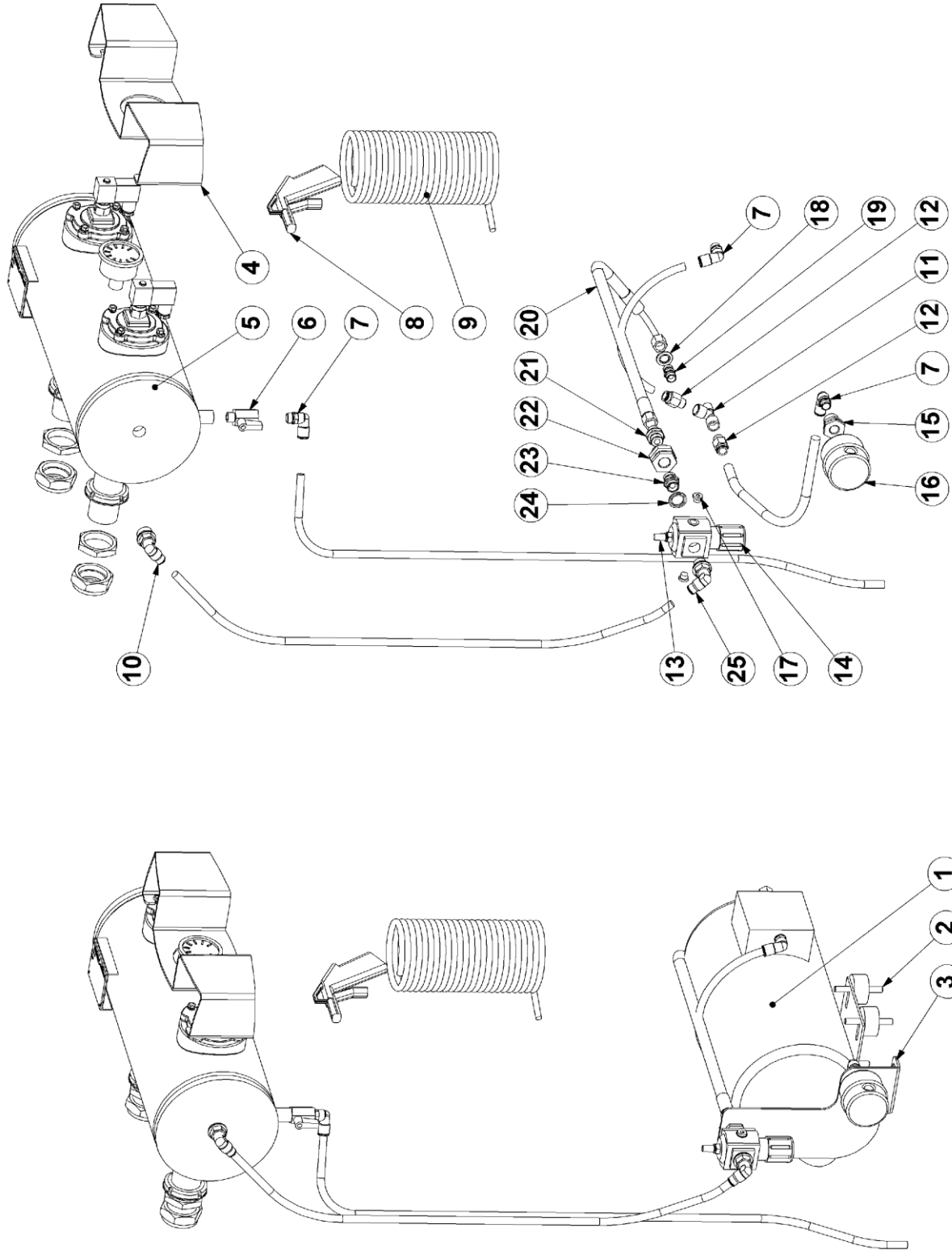

Fig. 02

Item	Part number	Description	Qty.
1	E06933	Compressor	1
2	999-9106	Shock absorber A40-20	4
3	E09913	Water separator mounting plate	1
4	E07756	Protection pulse valve	1
5	E07554	Pulse valve system	1
6	E14003	Mini ball valve 1/4" m/f bsp	1
7	E06923	Adaptor knee 10mm x 1/4" mbsp, swivel	3
8	DA--9290.1	Airpistol	1
9	DA--9290.2	Airhose 6 MM. L 5 MTR.	1
10	B20057	Connector Angle swiveling	1
11	E03215	T-nipple F-F-M 1/4"	1
12	E00674	Hose conn.straight 10x1/4"mbsp	2
13	E00034	Reduction silencer 1/4"	1
14	E06948	Pressure valve V72G-3GK-NMN	1
15	E03158	Panel mount conn. 1/4x M20	2
16	E06935	Filter FS-04-025	1
17	E06968	Plug 1/8"	2
18	E06972_1	Bonded seal 1/4"	1
19	E07585	Adapter male 1/4" BSP straight x male 1/4"	1
20	E07586	Hydr. Hose 1/4" met 1/4" fem.swivel straight	1
21	E07587	Adapter Straight 3/8"x 1/4" steel	1
22	E01927	Panel mount.conn.3/8xM26	1
23	E07588	Adapter straight 3/8" x 3/8" steel	1
24	E06970_1	Bonded seal 3/8"	1
25	E04620	Connector Angle swiveling	1

Fig. 03

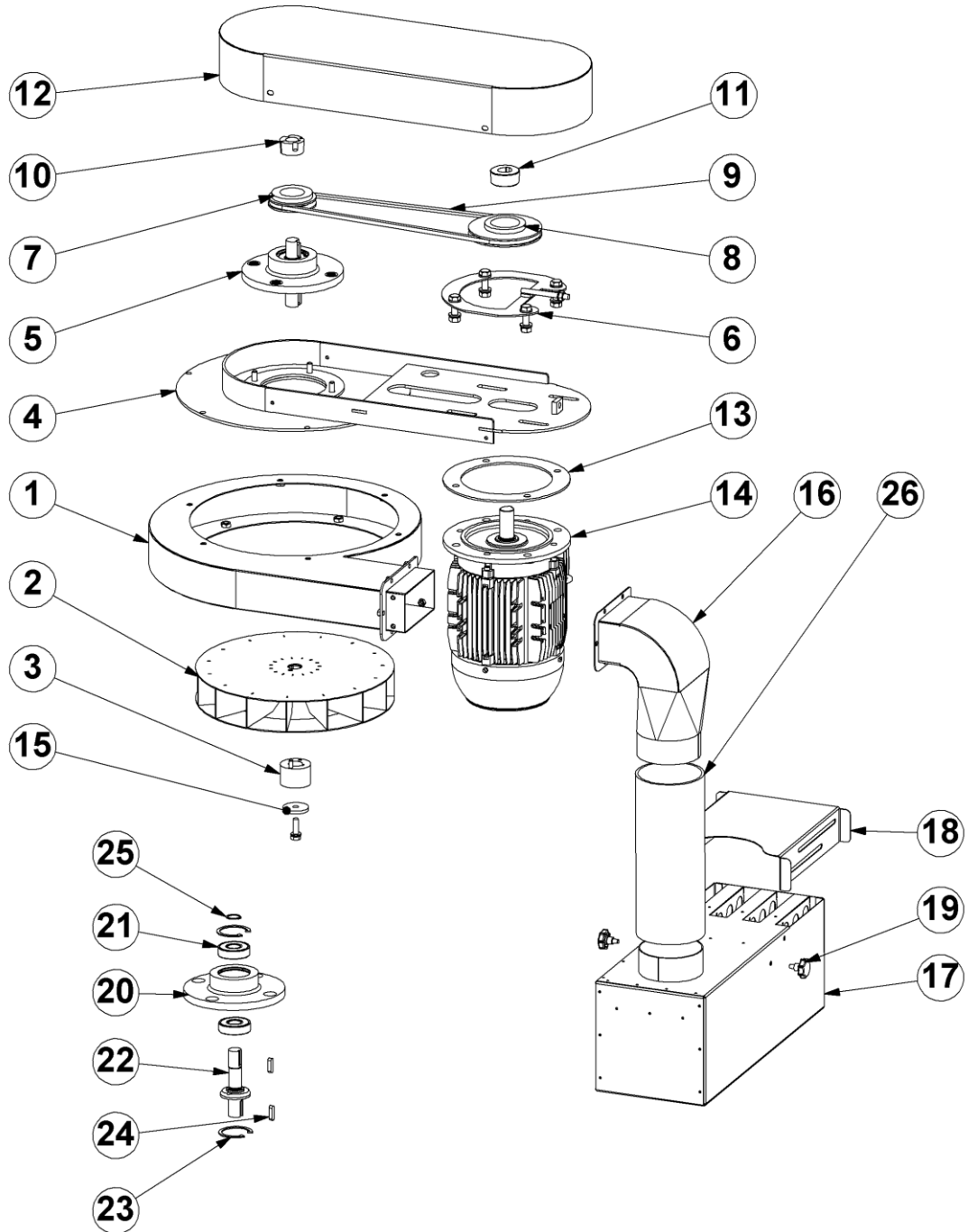

Fig. 03

Item	Part number	Description	Remarks	Qty.
1	E07501	Fan housing		1
2	E07439	Fan impeller type 1		1
3	E06965	Fan hub		1
4	E07507	Motor mounting bracket		1
5	E07594	BU fan unit (set)		1
6	E07067	Tension plate		1
7	E07559	Motor pulley	50Hz	1
	E07584	Motor pulley	60Hz	1
8	E07583	Motor pulley	50Hz	1
	500-2469	Motor pulley	60Hz	1
9	E07561	V-belt		1
10	E07254	Taperlock		1
11	976657	Taperlock		1
12	E07070	Belt guard		1
13	E07069	Fill up ring fan motor		1
14	E07580-IE3	Motor 5,5kW / 3000RPM		1
15	E03195	Ring fan		1
16	E09897	Silencer&Hepa adapter		1
17	E09878	Silencer		1
18	E09979	Silencer top cover		1
19	-----	Turning knob M8x15		2
20	E00702	Fan adapter bearing house		1
21	E00705	Bearing		2
22	E07517	Fan shaft		1
23	36050.062.001	Rataining ring		2
24	-----	Spie		2
25	-----	Circlip for shaft		1
26	-----	Hose Ø125mm		1

Fig. 04

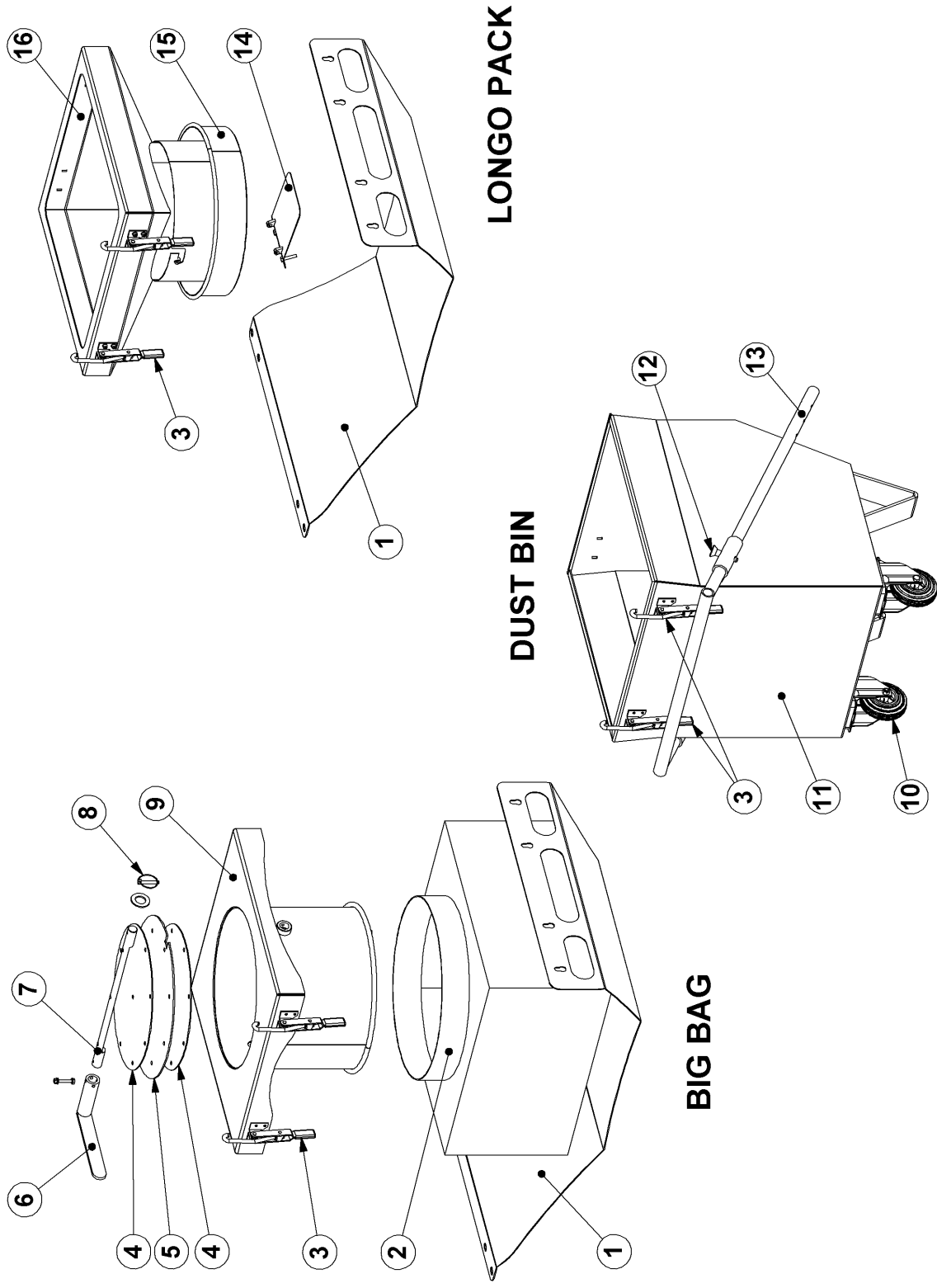

Fig. 04

Item	Part number	Description	Qty.
1	E09903	Bottom plate	1
2	E06311	Dust bag	1
3	483551	Clamp	2
4	E04623	Valve plate	2
5	E04624	Rubber plate valve	1
6	E07703	Valve handle	1
7	E04622	Valve axle	1
8	BE0116	Linch pin	1
9	E07627	Big bag bracket	1
10	E06887	Wheel	2
11	E07621	Dust bin	1
12	478198	Quick release pin	2
13	E07623	Handle bracket	1
14	E07654	Longo pack valve	1
15	E07655	Longo pack bracket	1
16	E07353	Longo pack hopper	1



Fig. 05

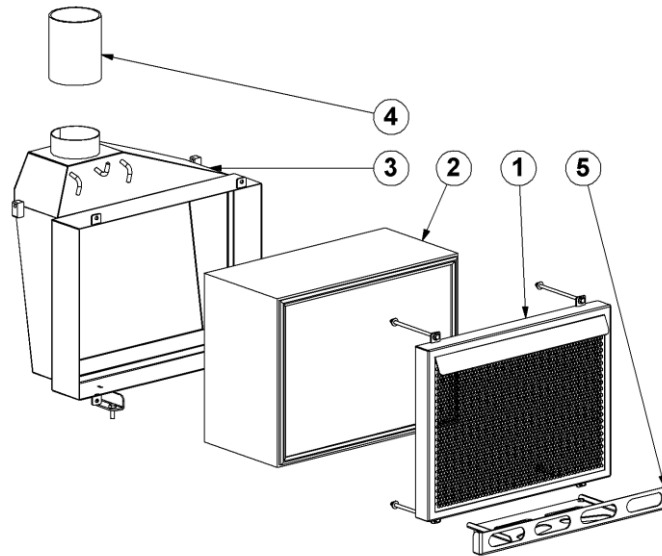

Fig. 05

Item	Part number	Description	Qty.
1	E09120	Front cover	1
2	E09117	Hepa filter class H13	1
	E11024	Hepa filter class H14	1
3	E09116	Back cover	1
4	---	Hose Ø125	1
5	E09911	Fender	1

Fig. 06

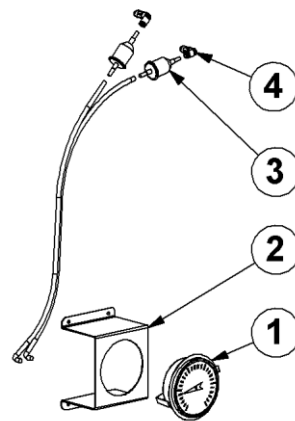

Fig. 06

Item	Part number	Description	Qty.
1	491837	Difference pressure measure	1
2	E11036	Bracket	1
3	2381-365	Filter vacuum gauge	2
4	E11039	Elbow male adaptor	2



13201 North Santa Fe Avenue • Oklahoma City, OK 73114 • Ph: 800-256-3440 • F: 405-478-8608 blastrac.com

Product Warranty

Standard Equipment Products:

Blastrac warrants its Blastrac Standard Equipment Products against defects in quality of material and workmanship, under normal and proper use for a period of **1 Year** from the date of delivery, as noted on the returned warranty registration card, or, in the case of **Rental Fleet Machines, 180 Days** from the date of assignment to Rental Fleet. This warranty is non-transferable and is extended to machines purchased and entered into the normal service of surface preparation by a recognized professional or qualified contractor. Blastrac makes this warranty only to the buyer who purchases the products directly from Blastrac or its Authorized Distributor. This warranty does not include expendable parts such as, but not limited to, blades, blast wheels, wear plates, liners, seals, and electrical components. All purchased parts utilized in the manufacture will be honored to the original manufacturer's specified warranty.

If the buyer does not return the warranty card or register the product online at www.blastrac.com within 30 days after taking delivery of Blastrac Standard Equipment Products, the warranty period is limited to 6 months from the date of delivery noted on shipping receipt.

Hand Tool Products:

Blastrac warrants its BLASTRAC Hand Tool Products, including hand grinders and accessories, against defects in material and workmanship under normal and proper use for a period of **90 days** from the date of delivery or, in the case of Rental Fleet Machines, from the date of assignment to a Rental Fleet. Blastrac makes this warranty only to the buyer who purchases the products directly from Blastrac or its authorized distributor. This warranty does not include expendable parts such as blades.

If the buyer does not return the warranty card, or register online at www.blastrac.com within 15 days after taking delivery of Blastrac Hand Tool Products, the warranty period is limited to 30 days from the date of delivery noted on shipping receipt.

WARRANTY TERMS AND CONDITIONS:

1. Blastrac's obligation under this warranty is limited to the replacement or repair, at Blastrac's option, of products and does not include, labor, the cost of transportation, loss of operating time, or normal maintenance services.
2. This warranty does not apply to failure occurring as a result of abuse, misuse, negligence, corrosion, erosion, normal wear and tear, alterations or modifications made to products without the express written consent of Blastrac.
3. The buyer must submit all warranty claims no later than thirty (30) days after buyer becomes aware of the basis for any such claim, or should have become aware of the basis for any such claim in the exercise of reasonable diligence.

To return parts for warranty consideration, please call Blastrac Customer Service at **800-256-3440**. Your customer service representative will obtain the necessary information to complete the Blastrac Returned Merchandise Authorization (RMA) Form. Blastrac will then send the RMA form to the customer authorizing the return of the parts for warranty evaluation. The parts must be received within sixty (60) days following the RMA origination date or the warranty claim will be denied. Once the parts are received they will be evaluated for warranty.

If the customer cannot wait for the evaluation/replacement of the parts during this process, the customer must issue a new purchase order to Blastrac for the replacement parts before they can be shipped. Once the evaluation process is complete and parts are deemed a valid warranty claim, a credit will be issued against this invoice.

4. The buyer may not return Blastrac products without written authorization to do so through a Blastrac RMA.

5. Blastrac reserves the right to inspect and determine the scope of its warranty responsibilities for any returned Blastrac products.

6. Blastrac makes no warranty with respect to accessories it does not manufacture, including but not limited to, engines, motors, batteries, tires and all other parts. See component manufacture warranty.

7. Blastrac reserves the right to make product changes or improvements without prior notice and without undertaking any obligation for such changes or improvements on previously sold products.

8. The above warranty conditions can only be altered by Blastrac. Blastrac must confirm alterations in writing for each specific transaction.

9. Blastrac reserves the right to modify this warranty for used or demo products on an individual transaction basis. Blastrac will include warranty modifications on its invoices for used or demo products.

10. BLASTRAC DOES NOT AUTHORIZE ANY PERSON, REPRESENTATIVE, SERVICE OR SALES OUTLET TO MAKE ANY WARRANTY DIFFERENT FROM THIS PRODUCT WARRANTY.

11. EXCEPT FOR ITS PRODUCT REPAIR OR REPLACEMENT OBLGATIONS DESCRIBED IN THIS PRODUCT WARRANTY, UNDER NO CIRCUMSTANCES SHALL BLASTRAC BE LIABLE TO THE BUYER, OR ANY OTHER PERSON, FOR ANY DIRECT, INCIDENTAL, OR CONSEQUENTIAL DAMAGES RESULTING FROM THE USE OF THE BLASTRAC PRODUCT, OR FOR ANY SPECIAL OR CONSEQUENTIAL DAMAGES OF ANY CHARACTER, INCLUDING WITHOUT LIMITATIONS, DAMAGES FOR ANY LOSS OF GOODWILL, WORK STOPPAGE, OR ANY AND ALL OTHER COMMERCIAL DAMAGES OR LOSSES.

12. BLASTRAC MAKES NO OTHER PRODUCT WARRANTIES, EXPRESS OR IMPLIED, INCLUDING, BUT NOT LIMITED TO, THE IMPLIED WARRANTIES OF MERCHANTABILITY AND FITNESS FOR A PARTICULAR PURPOSE.



IMPORTANT!

TO THE DELIVERING DISTRIBUTOR OR END USER

To ensure the proper warranty coverage is extended to the owner of this machine, fill in the necessary information below **COMPLETELY** and **ACCURATELY** and retain for your records. **Go to www.blastrac.com and register online.** Click on the Register icon in the left column of the homepage, and fill out the product registration form with the same information that will be recorded here.

The warranty period will start upon the delivery date of the machine.

The distributor or the end user must provide the machine warranty information when the machine is delivered. Registration of the machine will extend the warranty period from the recorded delivery date entered with product registration. **Failure to comply will make any and all warranties on the equipment void after 6 months.**

OWNER/END USER'S REFERENCE INFORMATION

Delivery Date _____	Machine Model No. _____
Delivering Distributor's Name and Address _____	Machine Serial No. _____
_____	Modifications _____
_____	_____
_____	_____
_____	_____
_____	_____
Signature of Delivering Distributor's Representative _____	_____

Blastrac is a registered trademark of Blastrac,NA
Fold and Detach Here if Mailing

Warranty Registration

IMPORTANT! To ensure that your Blastrac® machine is covered under warranty, please provide the information recorded here by registering online at blastrac.com, or complete this page and fax to 866-485-1046, or if you prefer, detach and mail to:

Blastrac, 13201 North Santa Fe Avenue, Oklahoma City, OK 73114-9901

(Please print legibly)

Company _____

Address _____

City, State, & Zip _____

Telephone No. _____ Contact Person _____

Date of Purchase _____ Date Received _____

Machine Model No. _____ Serial No. _____

Distributor Name _____

End User Name _____

End User E-mail _____



Blastrac
13201 North Santa Fe Avenue
Oklahoma City, OK 73114
800-256-3440
Fax: 866-485-1046
www.blastrac.com

